



# HBP-2000-4-3 BLOWER PURGE DESICCANT AIR DRYER GENERAL ARRANGEMENT

TOLERANCES UNLESS OTHERWISE SPECIFIED:

- FRACTIONS = ± 1/4 "
- ANGLES = ± 3°
- INCHES = ± 1/2 "
- FINISH = 250

THE SPECIFICATIONS AND DRAWINGS DISCLOSED HEREIN ARE THE SOLE PROPERTY OF ALTEC AIR, AND SHALL NOT BE COPIED OR USED AS THE BASIS FOR SALE OR MANUFACTURE WITHOUT EXPRESS WRITTEN PERMISSION.

### REVISION LOG

REV.	ECO.	DESCRIPTION	DATE	APPROVED
A				

DRAWING NO. **AT20-1143** REV. **A**

DRAWN: WS DATE: 11/27/2018  
CHECKED: DATE:

SCALE: N/A SHEET: 1 OF 2

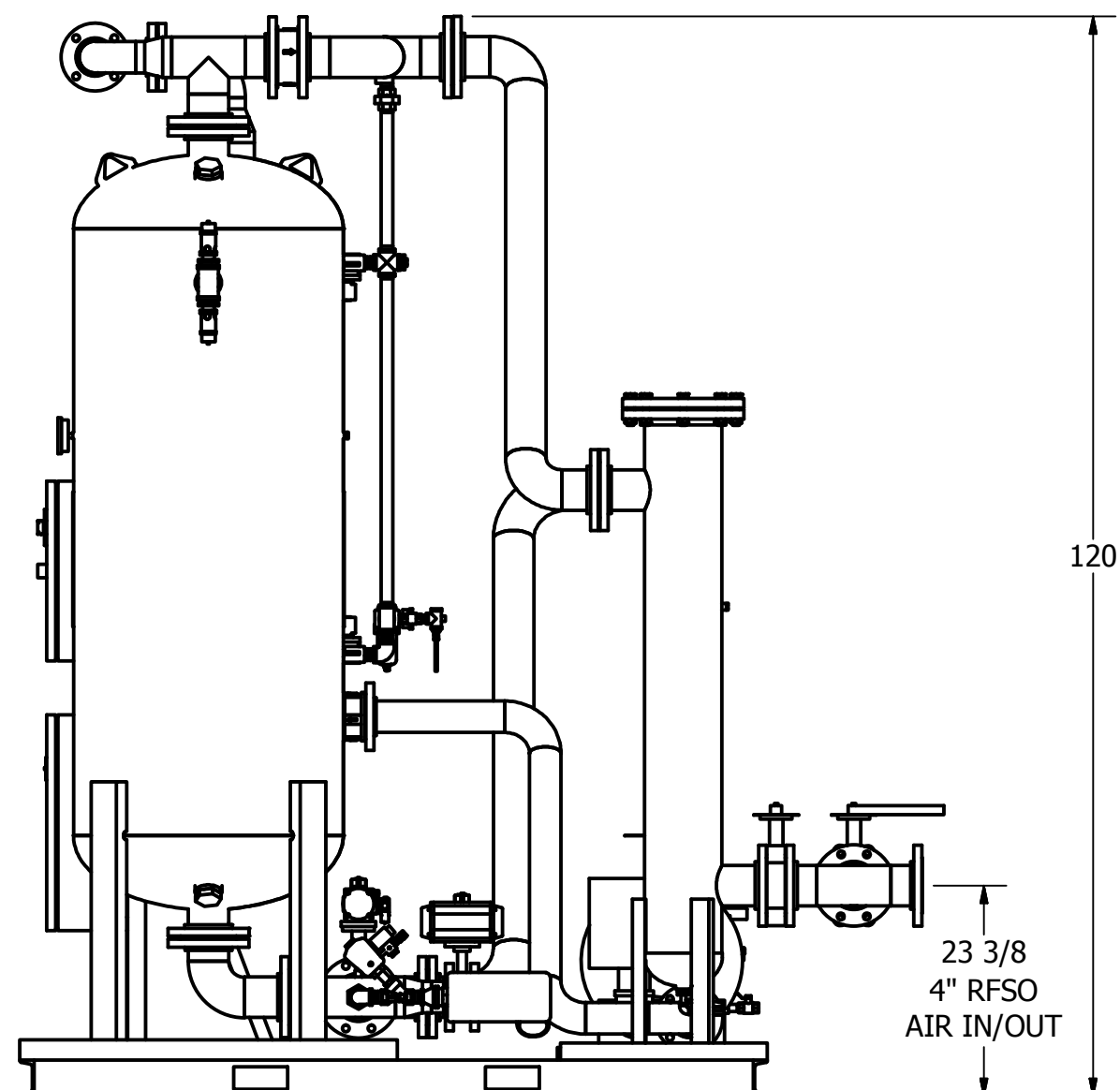
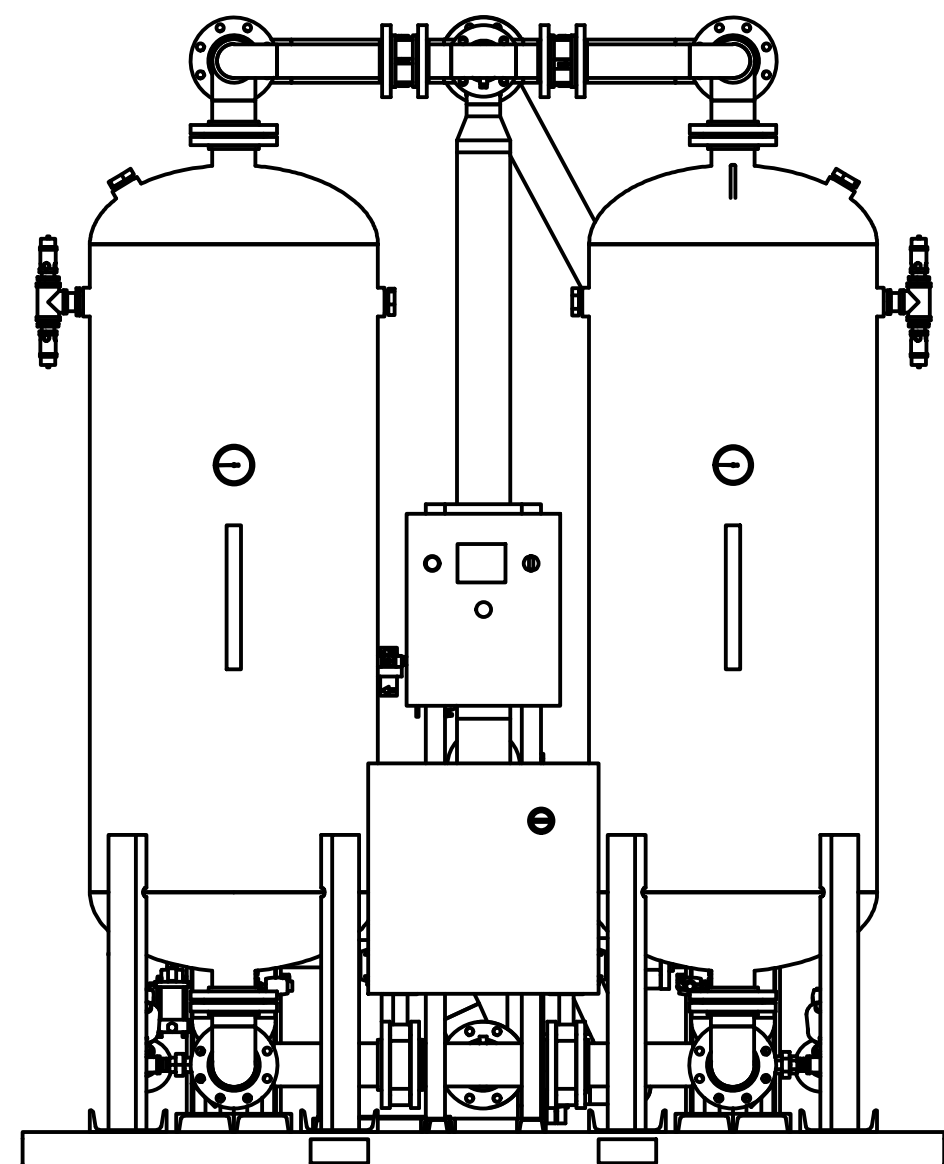
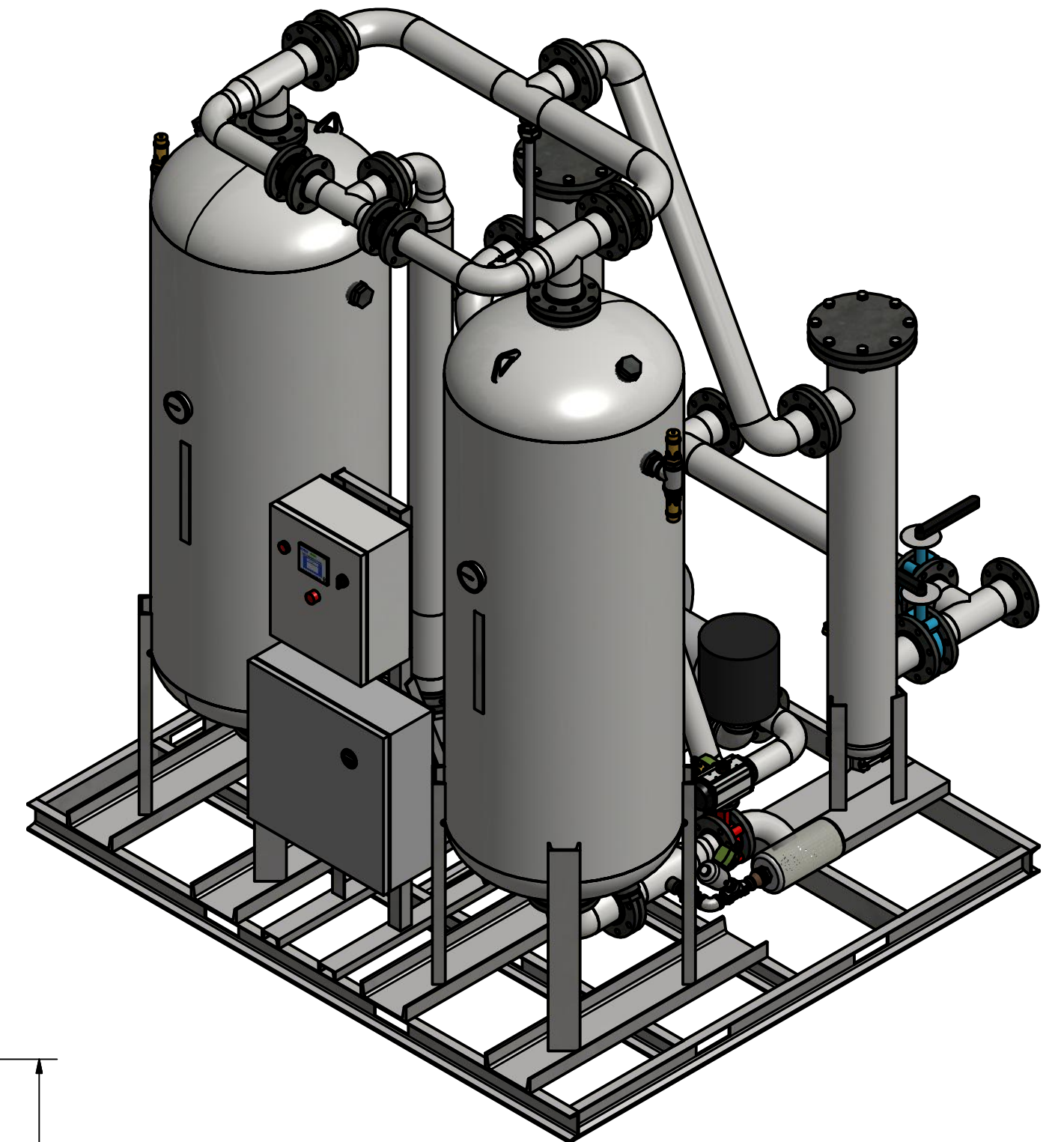
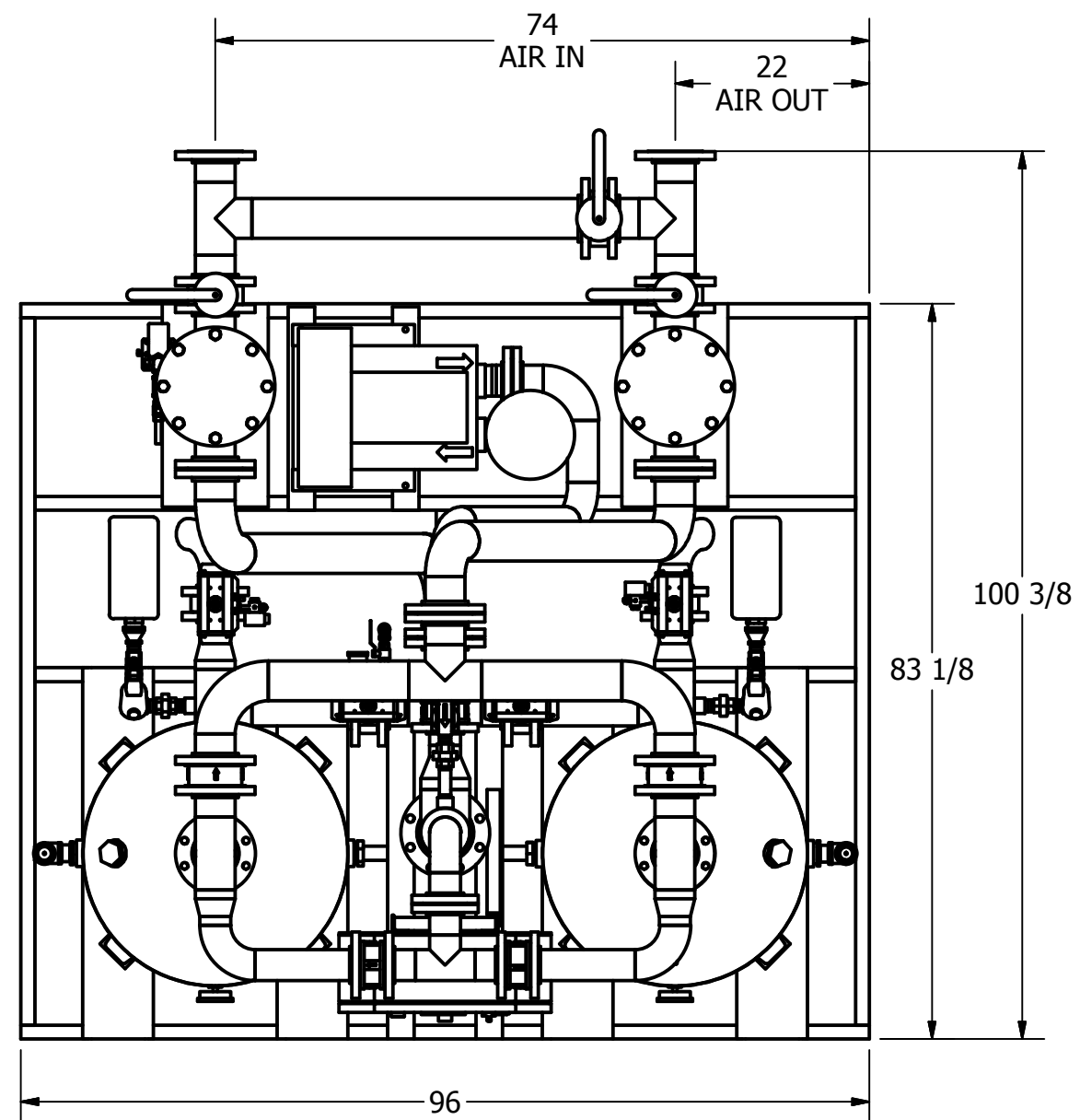

**PRELIMINARY**



# HBP-2000-4-3 BLOWER PURGE DESICCANT AIR DRYER GENERAL ARRANGEMENT

TOLERANCES UNLESS OTHERWISE SPECIFIED:

FRACTIONS = ± 1/4 "  
 ANGLES = ± 3°  
 INCHES = ± 1/2 "  
 FINISH = 250

THE SPECIFICATIONS AND DRAWINGS DISCLOSED HEREIN ARE THE SOLE PROPERTY OF ALTEC AIR, AND SHALL NOT BE COPIED OR USED AS THE BASIS FOR SALE OR MANUFACTURE WITHOUT EXPRESS WRITTEN PERMISSION.

### REVISION LOG

REV.	ECO.	DESCRIPTION	DATE	APPROVED
A				

DRAWING NO. **AT20-1143** REV. **A**

DRAWN: WS DATE: 11/27/2018  
 CHECKED: DATE:

SCALE: N/A SHEET: 2 OF 2

### PARTS LIST

ITEM	QTY	DESCRIPTION
1	2	CHECK VALVE, PURGE
2	2	CHECK VALVE, OUTLET
3	1	SOLENOID VALVE, REPRESS
4	1	PARTICULATE FILTER, CONTROL
5	1	MOISTURE INDICATOR
6	1	PRESSURE REGULATOR, CONTROL
7	1	PRESSURE GAUGE, CONTROL
8	1	DEW POINT MONITOR (OPTIONAL)
9	1	SOLENOID VALVE, 2%
10	1	CHECK VALVE, BLOWER
11	4	RELIEF VALVE, TANK
12	1	30 KW HEATER
13	2	PRESSURE GAUGE, TANK
14	1	COALESCER PRE-FILTER
15	1	ZERO LOSS DRAIN
16	1	7 1/2 HP BLOWER
17	1	FILTER, BLOWER
18	2	BUTTERFLY VALVE, INLET
19	2	BUTTERFLY VALVE, EXHAUST
20	2	ANGLE BODY VALVE, PRE-EXHAUST
21	2	MUFFLER, PRE-EXHAUST
22	1	PARTICULATE AFTER-FILTER
23	3	MANUAL BUTTERFLY VALVE, BYPASS
24	2800 LBS	DESICCANT

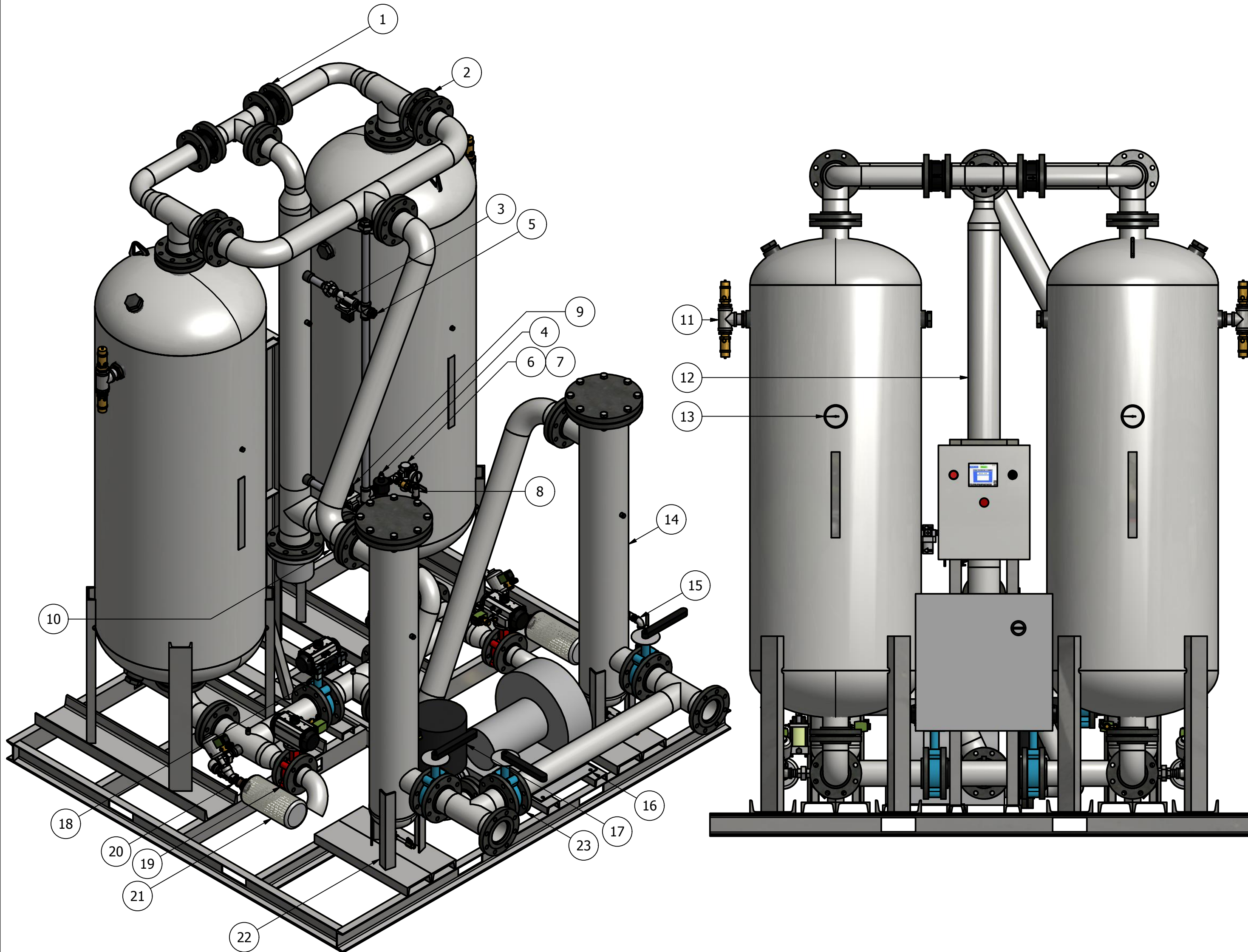

**PRELIMINARY**